

STRAIGHT PLUG CRIMP TYPE

R112.075.000

CABLE 2.6/50+75 S

Series : SMC

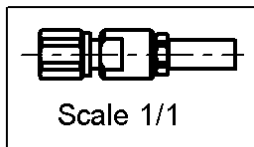
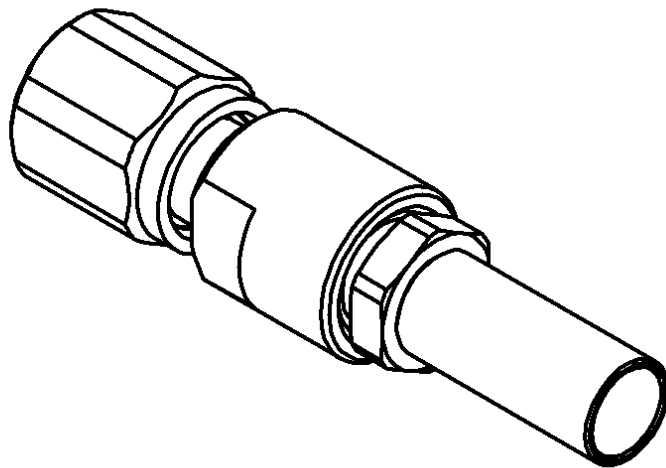
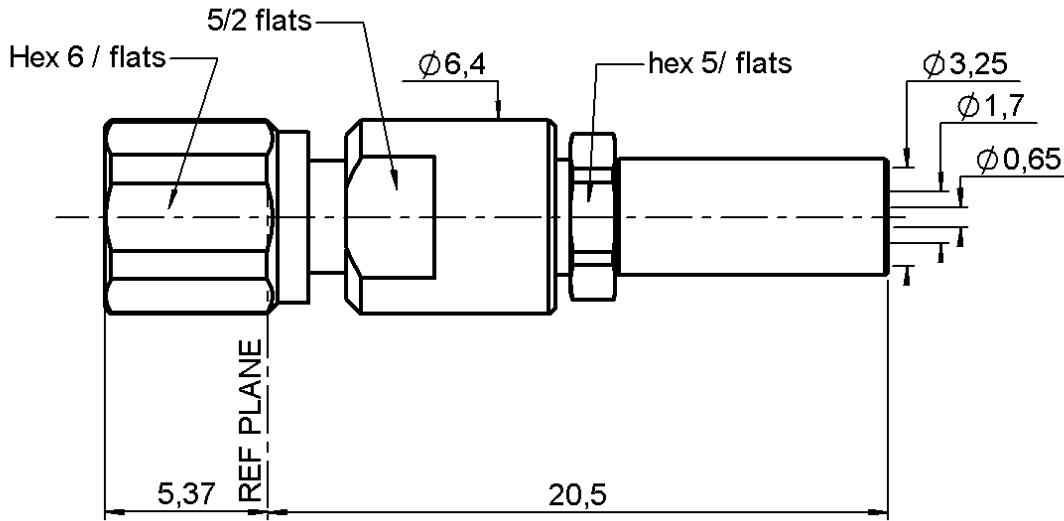

All dimensions are in mm.

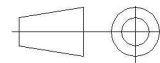

COMPONENTS	MATERIALS	PLATINGS (µm)
BODY	BRASS	GOLD 0.2 OVER NICKEL 2
CENTER CONTACT	BERYLLIUM COPPER	GOLD 1.3 OVER NICKEL 2
OUTER CONTACT	-	-
INSULATOR	PTFE	-
GASKET	-	-
OTHERS PARTS	BRASS	GOLD 0.2 OVER NICKEL 2
-	-	-
-	-	-

Issue : 0430 B

In the effort to improve our products, we reserve the right to make changes judged to be necessary.



STRAIGHT PLUG CRIMP TYPE

CABLE 2.6/50+75 S

R112.075.000

Series : SMC

PACKAGING

Standard	Unit	Other
1	-	Contact us

SPECIFICATION

ELECTRICAL CHARACTERISTICS

Impedance		50 Ω
Frequency		0-10 GHz
VSWR	1.20 +	0.040 x F(GHz) Maxi
Insertion loss		0.125 √F(GHz) dB Maxi
RF leakage	- (62 - F(GHz)) dB Maxi
Voltage rating		335 Veff Maxi
Dielectric withstanding voltage		1000 Veff mini
Insulation resistance		1000 MΩ mini

CABLE ASSEMBLY

Stripping	a	b	c	d	e	f
mm	2.20	5.40	15.5	0.00	13.3	0.00

Assembly instruction :

Recommended cable(s)

RG 179
KX 22A
RG 187
RG 188
RG 316

Characteristics indicated on this data sheet are those that can be achieved with the highest performance cable. Intrinsic limitations of the cable may diminish the performance of the assembly

Cable retention

- pull off **110** N mini
- torque **NA** N.cm

MECHANICAL CHARACTERISTICS

Center contact retention		
Axial force – Mating end	10	N mini
Axial force – Opposite end	10	N mini
Torque	NA	N.cm mini

TOOLING

Part Number	Description	Hexagon
.	.	.
R282.211.000	CRIMPING TOOL	3.25
R282.235.003	CRIMPING DIES	3.25
R282.293.000	CRIMPING TOOL	-

Recommended torque		
Mating	30	N.cm
Panel nut	NA	N.cm
Clamp nut	70	N.cm
A/F clamp nut	5.000	mm

Mating life	500	Cycles mini
Weight	0.000	g

OTHERS CHARACTERISTICS

ENVIRONMENTAL

Operating temperature	-65/+165	°C
Hermetic seal	NA	Atm.cm3/s
Panel leakage	NA	

Issue : 0430 B

In the effort to improve our products, we reserve the right to make changes judged to be necessary.



STRAIGHT PLUG CRIMP TYPE

R112.075.000

CABLE 2.6/50+75 S

Series : SMC

COMPONENTS

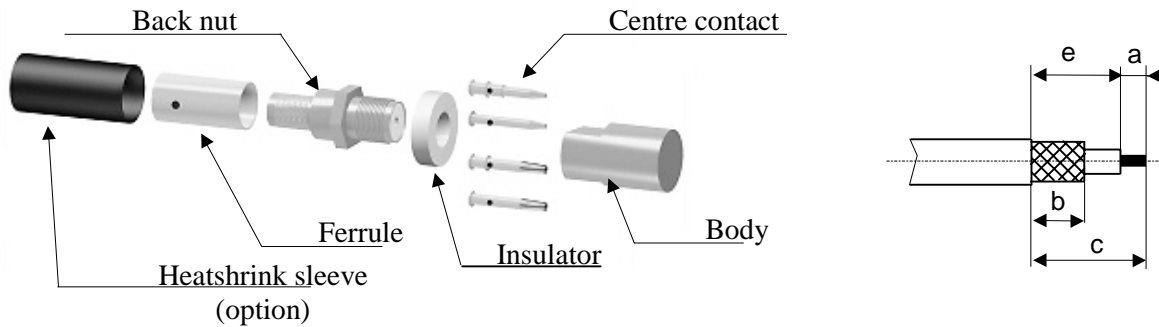

1

Slide the heatshrink sleeve onto the cable (Option).
Slide the ferrule onto the cable.
Position the ferrule's hole at the front if soldering.
Position the ferrule's hole at the back if crimping.
Strip the cable.

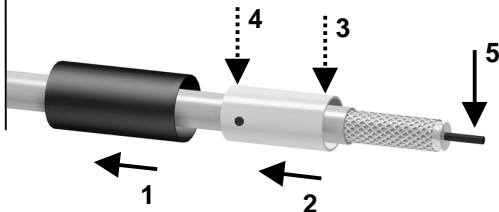

4

Slide the centre contact on until it bottoms against the insulator back nut.
Solder or crimp the contact (see connector TDS).

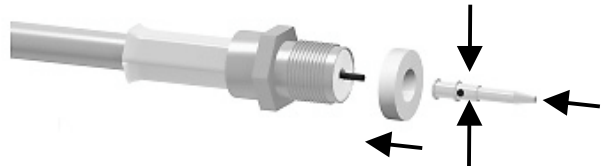

2

Fan the braid.
Slide the cable into the back nut.

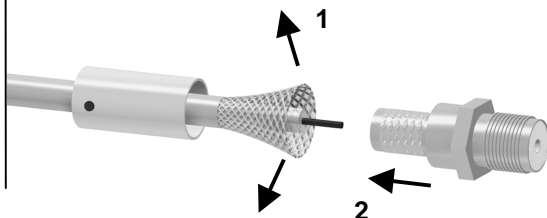

5

Screw the back nut into the connector body with the adapted wrench.
Recommended coupling torque 63 to 70 N cm.

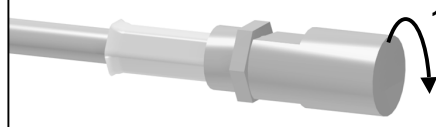

3

Slide the ferrule over the braid.
Crimp the ferrule with crimping tool (see connector TDS).

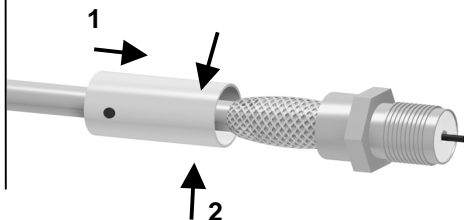

6

Slide the sleeve over the ferrule and heatshrink it in place (option).

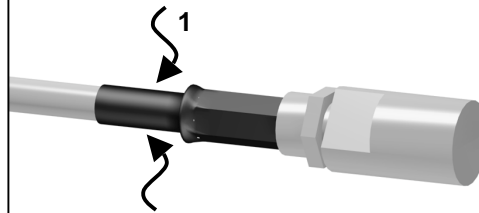

Issue : 0430 B

In the effort to improve our products, we reserve the right to make changes judged to be necessary.



RADIALL®

Mouser Electronics

Authorized Distributor

Click to View Pricing, Inventory, Delivery & Lifecycle Information:

[Radial:](#)

[R112075000](#)