

# 200GHz Dense Wavelength Division Multiplexer



ACP's 200GHz Dense Wavelength Division Multiplexer (DWDM) utilizes thin film coating technology and proprietary design of non-flux metal bonding micro optics packaging to achieve optical add and drop at the ITU wavelength. It provides ITU channel center wavelength, low insertion loss, high channel isolation, wide pass band, low temperature sensitivity and epoxy free optical path . It can be used for wavelength add/drop in telecommunication network system.

All AC Photonics' products are Telcordia qualification tested.

## PERFORMANCE SPECIFICATIONS

Parameter		Mux/Demux			
Channel Wavelength		ITU 100GHz Grid			
Minimum Channel Spacing		200GHz			
Center Wavelength (CWL) Accuracy		±0.1nm			
Channel Passband (@-0.5dB bandwidth)		≥ 0.5nm			
1310nm Express Channel Wavelength		1260 to 1360nm			
UPG Channel Wavelength		1528 to 1563nm (except drop channels)			
Max. Insertion Loss (COM to Ch. and COM to UPG)	Option	U0 <sup>1)</sup>	U1 <sup>2)</sup>	U2/U4 <sup>3)</sup>	U3/U5 <sup>4)</sup>
	4ch	≤1.6dB	≤1.7dB	≤1.9dB	≤2.0dB
	8ch	≤2.5dB	≤2.6dB	≤2.8dB	≤2.9dB
	16ch	≤3.8dB	≤3.9dB	≤4.1dB	≤4.2dB
1% TAP Port Loss		20.4dB			
1310nm Express Port Loss		≤ 1.4dB			
Channel Uniformity	4ch	≤ 0.6dB			
	8ch	≤ 1.0dB			
	16ch	≤ 1.5dB			
Channel Ripple		≤ 0.4dB			
Channel Isolation (Adjacent) (Demux only)		≥ 30dB			
Channel Isolation (Non-Adjacent) (Demux only)		≥ 40dB			
Insertion Loss Temperature Sensitivity		≤ 0.003dB/°C			
Wavelength Temperature Shifting		≤ 0.002nm/°C			
Polarization Dependent Loss		≤ 0.10dB			
Polarization Mode Dispersion		≤ 0.10ps			
Directivity		≥ 50dB			
Return Loss		≥ 45dB			
Optical Power		≤ 300mW			
Operating Temperature		0 to +70°C 0 to +70 (Extended temperatures are also available upon request)			
Storage Temperature		- 40 to +85°C			
Package Dimensions (LxWxH)		S= 89x51x8.0mm case (4 Ch) F= 96x78x8mm case (4/8 Ch) G=96x78x13mm case (16/20 Ch) L1=Single LGX Box (4/8 Ch, Maximum 16 Ch with LC) L2=Double LGX Box; R1=19" Rack (1RU)			

## FEATURES

- 200GHz ITU Channel Spacing
- Low Insertion Loss
- Wide Pass Band
- High Channel Isolation
- High Stability and Reliability
- Epoxy Free Optical Path

## APPLICATION

- Channel Add/Drop
- DWDM Networks
- Wavelength Routing
- Fiber Optical Amplifier
- CATV Fiberoptic System

Note:

- 1) U0: UPG (Upgrade) port
- 2) U1: 1% Tap + UPG port
- 3) U2: 1310nm port, U4: 1310nm + UPG port
- 4) U3: 1310nm + 1% Tap port  
U5: 1310nm + UPG + 1% Tap port

All values referenced are without connector.

## 200GHz Dense Wavelength Division Multiplexer

### MECHANICAL DIMENSIONS

S package:

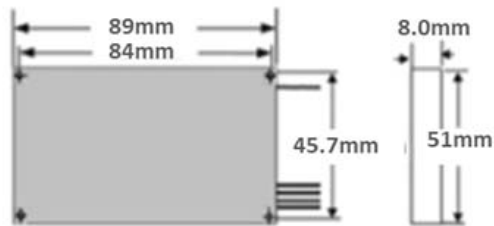

F/G package:

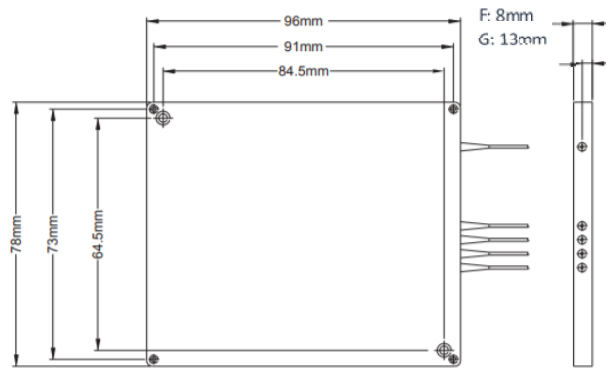

Single LGX Box

Double LGX Box

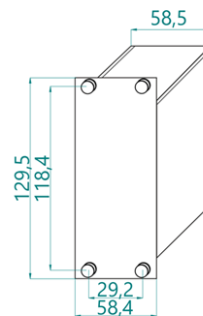
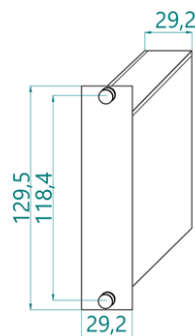

19" Rack:

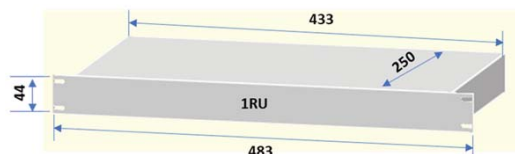

## 200GHz Dense Wavelength Division Multiplexer

### CHANNEL CONFIGURATIONS

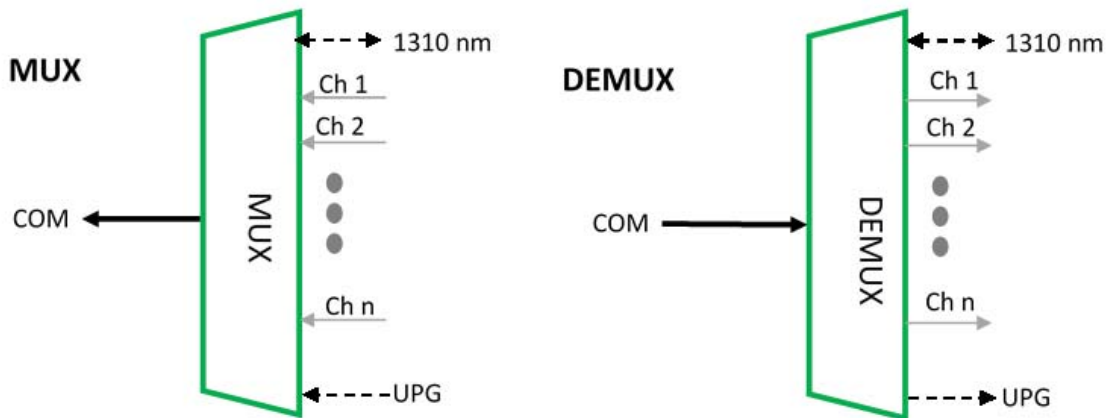

### ORDERING INFORMATION

Channel Spacing	Number of Channels	Configuration	1st (ITU) Channel**	Package	Fiber Type***	Pigtail Style	Fiber Length	In Connector	Out Connector	Option
2=200GHz	02=2 Channel	M=Mux	C21=1560.61nm	S=S package	None=L1, L2 & R1 Package	None=L1, L2 & R1 Package	None=L1, L2 & R1 Package	0=None	0=None	None=Standard
	04=4 Channel	D=Demux	C22=1559.79nm	F= F package				1=FC/APC	1=FC/APC	U0=UPG
	•		•	G= G package	2=SMF-28 Ultra	1=Bare fiber	05=0.5m	2=FC/PC	2=FC/PC	U1=1% + UPG
	•		•	L1=Single LGX	(G.657.A1)	2=900um	10=1.0m	3=SC/APC	3=SC/APC	U2=1310
	•		•	L2=Double LGX	3=ClearCurve	loose tube	•	4=SC/PC	4=SC/PC	U3=1310+1%
	16=16 Channel		C61=1528.77nm	R1=19"1RU	ZBL(G.657.B3)	3=3mm jacket	•	5=ST	5=ST	U4=1310+UPG
	20=20 Channel*					4=2mm jacket	•	6=LC/UPC	6=LC/UPC	U5=1310+UPG+1%
						5=1.6mm jacket	20=2.0m	7=LC/APC	7=LC/APC	

\* 20 channels are also available upon request, but we cannot provide UPG for 20ch.

\*\*O and L band wavelengths are also available upon request.

\*\*\*1=SMF-28(G.652) is available upon request.

## 200GHz Dense Wavelength Division Multiplexer

### ITU TABLE

Channel	f (GHz)	$\lambda$ (nm)	Channel	f (GHz)	$\lambda$ (nm)	Channel	f (GHz)	$\lambda$ (nm)	Channel	f (GHz)	$\lambda$ (nm)
L48	184800	1622.25	Q76	187650	1597.62	C05	190500	1573.71	H33	193350	1550.52
Q48	184850	1621.81	L77	187700	1597.19	H05	190550	1573.30	C34	193400	1550.12
L49	184900	1621.38	Q77	187750	1596.76	C06	190600	1572.89	H34	193450	1549.72
Q49	184950	1620.94	L78	187800	1596.34	H06	190650	1572.48	C35	193500	1549.32
L50	185000	1620.50	Q78	187850	1595.91	C07	190700	1572.06	H35	193550	1548.91
Q50	185050	1620.06	L79	187900	1595.49	H07	190750	1571.65	C36	193600	1548.51
L51	185100	1619.62	Q79	187950	1595.06	C08	190800	1571.24	H36	193650	1548.11
Q51	185150	1619.19	L80	188000	1594.64	H08	190850	1570.83	C37	193700	1547.72
L52	185200	1618.75	Q80	188050	1594.22	C09	190900	1570.42	H37	193750	1547.32
Q52	185250	1618.31	L81	188100	1593.79	H09	190950	1570.01	C38	193800	1546.92
L53	185300	1617.88	Q81	188150	1593.37	C10	191000	1569.59	H38	193850	1546.52
Q53	185350	1617.44	L82	188200	1592.95	H10	191050	1569.18	C39	193900	1546.12
L54	185400	1617.00	Q82	188250	1592.52	C11	191100	1568.77	H39	193950	1545.72
Q54	185450	1616.57	L83	188300	1592.10	H11	191150	1568.36	C40	194000	1545.32
L55	185500	1616.13	Q83	188350	1591.68	C12	191200	1567.95	H40	194050	1544.92
Q55	185550	1615.70	L84	188400	1591.26	H12	191250	1567.54	C41	194100	1544.53
L56	185600	1615.26	Q84	188450	1590.83	C13	191300	1567.13	H41	194150	1544.13
Q56	185650	1614.83	L85	188500	1590.41	H13	191350	1566.72	C42	194200	1543.73
L57	185700	1614.39	Q85	188550	1589.99	C14	191400	1566.31	H42	194250	1543.33
Q57	185750	1613.96	L86	188600	1589.57	H14	191450	1565.90	C43	194300	1542.94
L58	185800	1613.52	Q86	188650	1589.15	C15	191500	1565.50	H43	194350	1542.54
Q58	185850	1613.09	L87	188700	1588.73	H15	191550	1565.09	C44	194400	1542.14
L59	185900	1612.65	Q87	188750	1588.30	C16	191600	1564.68	H44	194450	1541.75
Q59	185950	1612.22	L88	188800	1587.88	H16	191650	1564.27	C45	194500	1541.35
L60	186000	1611.79	Q88	188850	1587.46	C17	191700	1563.86	H45	194550	1540.95
Q60	186050	1611.35	L89	188900	1587.04	H17	191750	1563.45	C46	194600	1540.56
L61	186100	1610.92	Q89	188950	1586.62	C18	191800	1563.05	H46	194650	1540.16
Q61	186150	1610.49	L90	189000	1586.20	H18	191850	1562.64	C47	194700	1539.77
L62	186200	1610.06	Q90	189050	1585.78	C19	191900	1562.23	H47	194750	1539.37
Q62	186250	1609.62	L91	189100	1585.36	H19	191950	1561.83	C48	194800	1538.98
L63	186300	1609.19	Q91	189150	1584.95	C20	192000	1561.42	H48	194850	1538.58
Q63	186350	1608.76	L92	189200	1584.53	H20	192050	1561.01	C49	194900	1538.19
L64	186400	1608.33	Q92	189250	1584.11	C21	192100	1560.61	H49	194950	1537.79
Q64	186450	1607.90	L93	189300	1583.69	H21	192150	1560.20	C50	195000	1537.40
L65	186500	1607.47	Q93	189350	1583.27	C22	192200	1559.79	H50	195050	1537.00
Q65	186550	1607.04	L94	189400	1582.85	H22	192250	1559.39	C51	195100	1536.61
L66	186600	1606.60	Q94	189450	1582.44	C23	192300	1558.98	H51	195150	1536.22
Q66	186650	1606.17	L95	189500	1582.02	H23	192350	1558.58	C52	195200	1535.82
L67	186700	1605.74	Q95	189550	1581.60	C24	192400	1558.17	H52	195250	1535.43
Q67	186750	1605.31	L96	189600	1581.18	H24	192450	1557.77	C53	195300	1535.04
L68	186800	1604.88	Q96	189650	1580.77	C25	192500	1557.36	H53	195350	1534.64
Q68	186850	1604.46	L97	189700	1580.35	H25	192550	1556.96	C54	195400	1534.25
L69	186900	1604.03	Q97	189750	1579.93	C26	192600	1556.55	H54	195450	1533.86
Q69	186950	1603.60	L98	189800	1579.52	H26	192650	1556.15	C55	195500	1533.47
L70	187000	1603.17	Q98	189850	1579.10	C27	192700	1555.75	H55	195550	1533.07
Q70	187050	1602.74	L99	189900	1578.69	H27	192750	1555.34	C56	195600	1532.68
L71	187100	1602.31	Q99	189950	1578.27	C28	192800	1554.94	H56	195650	1532.29
Q71	187150	1601.88	L00	190000	1577.86	H28	192850	1554.54	C57	195700	1531.90
L72	187200	1601.46	Q00	190050	1577.44	C29	192900	1554.13	H57	195750	1531.51
Q72	187250	1601.03	C01	190100	1577.03	H29	192950	1553.73	C58	195800	1531.12
L73	187300	1600.60	H01	190150	1576.61	C30	193000	1553.33	H58	195850	1530.72
Q73	187350	1600.17	C02	190200	1576.20	H30	193050	1552.93	C59	195900	1530.33
L74	187400	1599.75	H02	190250	1575.78	C31	193100	1552.52	H59	195950	1529.94
Q74	187450	1599.32	C03	190300	1575.37	H31	193150	1552.12	C60	196000	1529.55
L75	187500	1598.89	H03	190350	1574.95	C32	193200	1551.72	H60	196050	1529.16
Q75	187550	1598.47	C04	190400	1574.54	H32	193250	1551.32	C61	196100	1528.77
L76	187600	1598.04	H04	190450	1574.13	C33	193300	1550.92	H61	196150	1528.38